

Fellowes

AIR PURIFIERS

AeraMax SE

Air Purifier | Purificateur d'air | Purificador de aire | Luftreiniger
Purificatore d'aria | Luchtreiniger | Luftrenare | Luftreenser | Ilmanpuhdistin
Luftreenser | Oczyszczacz powietrza | Воздухоочиститель | Ιονιστής | Hava
Temizleyici | Čistička vzduchu | Čistič vzduchu
Légtisztító készülék | Purificador de ar



Please read these instructions before use. Do not discard: keep for future reference.

Lire ces instructions avant utilisation. Ne pas jeter : conserver pour référence ultérieure.

Lea estas instrucciones antes de usarlo. No las deseche: guárdelas para tenerlas como referencia.

Diese Anleitungen vor Gebrauch genau durchlesen. Bitte nicht entsorgen: Zur späteren Bezugnahme aufheben.

Prima dell'uso, si raccomanda di leggere questo manuale di istruzioni. Conservare il manuale per consultarlo secondo le necessità.

Deze instructies voor gebruik lezen. Niet weggooien, maar bewaren om later te kunnen raadplegen.

Läs dessa anvisningar innan du använder apparaten. Släng inte bort, behåll för framtida bruk.

Læs venligst denne vejledning før anvendelse. Bør ikke bortskaffes. Behold for fremtidig henvisning.

Lue nämä ohjeet ennen käyttöä. Älä hävittää: säilytä myöhempää käyttöä varten.

Vennligst les nøye igjennom denne bruksanvisningen før bruk. Ikke kast den: Ta vare på den for senere referanse.

Przed użyciem proszę zapoznać się z tą instrukcją. Nie wyrzucać - zachować jako źródło informacji na przyszłość

Перед началом эксплуатации обязательно прочтите данную инструкцию. Не выбрасывайте данную инструкцию: сохраните ее для последующего использования.

Παρακαλείσθε να διαβάσετε αυτές τις οδηγίες πριν χρησιμοποιήσετε το προϊόν. Μην τις απορρίψετε: κρατήστε τις για μελλοντική αναφορά.

Kullanmadan önce lütfen bu talimatları okuyun. Atmayın: ileride başvurmak üzere saklayın.

Před použitím si přečtěte tyto pokyny. Nelikvidujte: uschovejte pro budoucí použití.

Pred použitím si prečítajte tieto pokyny. Nezhadzujte: odložte pre budúce použitie.

Kérjük, hogy használat előtt olvassa el az utasításokat! Az utasításokat ne dobja ki; tartsa meg referenciaanyagként való jövőbeni használatra.

Leia estas instruções antes da utilização. Não as deite fora: conserve-as para consulta futura.

TABLE OF CONTENTS

Warranty	2	Air Purifier Set-Up.....	5
Package Contents	2	Display Panel	6
Safety Instructions.....	2-3	Operation.....	7
Product Specifications.....	3	Care and Maintenance.....	8
Air Purifier Features.....	4	Troubleshooting	9

LIMITED PRODUCT WARRANTY

Limited Warranty: Fellowes, Inc. (“Fellowes”) warrants the parts of the machine to be free of defects in material and workmanship and provides service and support for 3 years from the date of purchase by the original consumer. If any part is found to be defective during the warranty period, your sole and exclusive remedy will be repair or replacement, at Fellowes’ option and expense, of the defective part. This warranty does not cover damage caused by use of non-Fellowes approved filters or failure to follow the recommended replacement schedule. This warranty does not apply in cases of abuse, mishandling, failure to comply with product usage standards, operation using an improper power supply (other than listed on the label), or unauthorized repair. Fellowes reserves the right to charge the consumers for any additional costs incurred by Fellowes to provide parts or services outside of the country where the air purifier is initially sold by an authorized reseller. This warranty does not include the air cleaner’s replaceable filters, this is an expendable part that can wear out from normal use before three years expire. ANY IMPLIED WARRANTY, INCLUDING THAT OF MERCHANTABILITY OR FITNESS FOR A PARTICULAR PURPOSE, IS HEREBY LIMITED IN DURATION TO THE APPROPRIATE WARRANTY PERIOD SET FORTH ABOVE. In no event shall Fellowes be liable for any consequential or incidental damages attributable to this product. This warranty gives you specific legal rights. The duration, terms, and conditions of this warranty are valid worldwide, except where different limitations, restrictions, or conditions may be required by local law. For more details or to obtain service under this warranty, please contact us or your dealer.

PACKAGE CONTENTS

- Fellowes® AeraMax™ Air Purifier
- Combination active carbon filter/true HEPA filter/pre-filter (1 filter)
- Instruction Sheet
- Survey Card

SAFETY INSTRUCTIONS

Thank you for purchasing a Fellowes® Air Purifier. Please read this manual carefully before using. This product is for indoor use only.

IMPORTANT CAUTIONS AND INSTRUCTIONS FOR USING YOUR AIR PURIFIER

WARNING: Follow the instructions in this manual to reduce the risk of electric shock, short circuit, and/or fire:

- Do not repair or modify the unit unless specifically recommended in this manual. All repairs should be completed by a qualified technician.
- Do not force the plug into an electrical outlet.
- Do not alter the plug in any way. If the plug does not fit into the outlet, reverse the plug. If it still does not fit, contact a qualified technician to install a proper outlet.
- Do not use if the power cord or plug is damaged or the connection to the wall outlet is loose.
- Do not damage, break, forcefully bend, pull, twist, bundle, coat, pinch, or place heavy objects on the power cord.
- Periodically remove dust from the power plug. This will reduce the chance that humidity will accumulate, which increases the risk of electric shock.
- If the supply cord is damaged, it must be replaced by the manufacturer, its service agent, or similarly qualified persons in order to avoid a hazard.
- Remove the power plug from the outlet before cleaning the unit. When removing the power plug, grasp by holding the plug itself, never hold by the cord.
- Remove the power plug from the outlet when the unit is not in use.

- Do not handle the power plug with wet hands.
- Do not operate the unit when using indoor smoke-generating insecticides.
- Do not clean unit with benzene or paint thinner. Do not spray insecticides on the unit.
- Do not use the unit where it is humid or where the unit may get wet, such as in a bathroom.
- Do not insert fingers or foreign objects into the air intake or outlet.
- Do not use the unit near flammable gases. Do not use near cigarettes, incense, or other spark-creating items.
- Unit will not remove carbon monoxide emitted from heating appliances or other sources.
- Do not block the intake or outlet vents.
- Do not use near hot objects, such as a stove. Do not use where the unit may come into contact with steam.
- Do not use the unit on its side.
- Keep away from products that generate oily residue, such as a deep fryer.
- Do not use detergent to clean the unit.
- Do not operate without a filter.
- Do not wash and reuse the True HEPA Filter.
- Do not run power cord under carpets or cover with throw rugs.
- When moving machine, always lift using handle.
- Do not place objects on top of the air purifier.
- Do not use air purifier with an extension cord.
- This appliance can be used by children aged from 8 years and above and persons with reduced physical, sensory or mental capabilities or lack of experience and knowledge if they have been given supervision or instruction concerning use of the appliance in a safe way and understand the hazards involved. Children shall not play with the appliance. Cleaning and user maintenance shall not be made by children without supervision.
- Warning: Not suitable for use with solid-state speed controls.
- For floor use only.

PRODUCT SPECIFICATIONS

PRODUCT SPECIFICATIONS	
	AeraMax™ SE Air Purifier
Room Area Served	527 sq. ft./50 sq. m.
Power Supply	AC 220-240V, 50/60Hz
Power Rate	70W
Fan Speed	3 Speeds
Display	Capacitive Touch
Control Type	Auto/Manual/Night/Child Lock
Air Quality Sensor	Yes
Filters	1 Combination True HEPA / Activated Carbon / Pre-Filter with an estimated filter life of 1 year.
Cleaning System	Carbon Filter True HEPA Filter with AeraSafe™ Antimicrobial Treatment
CADR	340 CFM
Color	White
Sound	68 dB
Dimensions	29.3 x 12.6 x 12.6 inches / 74.5 x 32.0 x 32.0 cm

FILTER SPECIFICATIONS

Combination Filter
(Carbon / True HEPA /
Pre-filter) Replacement

9787801

For replacement filters please visit: www.fellowes.com

Warning

Any changes or modifications not expressly approved by the manufacturer could void the user's authority to operate the equipment.

AIR PURIFIER FEATURES

- **Ultra-Quiet Operation**

This Fellowes AeraMax™ Air Purifier has a three-speed fan with ultra-quiet operation that is ideal for 24 hour use.

- **Easy Maintenance**

For optimum performance, replace the Combination Filter when the Filter indicator has illuminated, or approximately every 12 months under normal usage conditions.

- **AeraSmart™ Sensor**

This air purifier is equipped with an air quality sensor that automatically adjusts the fan speed to keep your air purified. Green, amber and red lights indicate the purity of your air.

- **Three-Speed Setting**

From LOW for quiet, energy-efficient operation to TURBO for the most effective cleaning.

- **Replacement Filter Indicator Lights**

Indicate when to replace the True HEPA Filter and Carbon Filter, depending on usage.

THREE-STAGE PURIFICATION SYSTEM

- **Carbon Filter**

- **True HEPA Filter**

- **Prefilter**

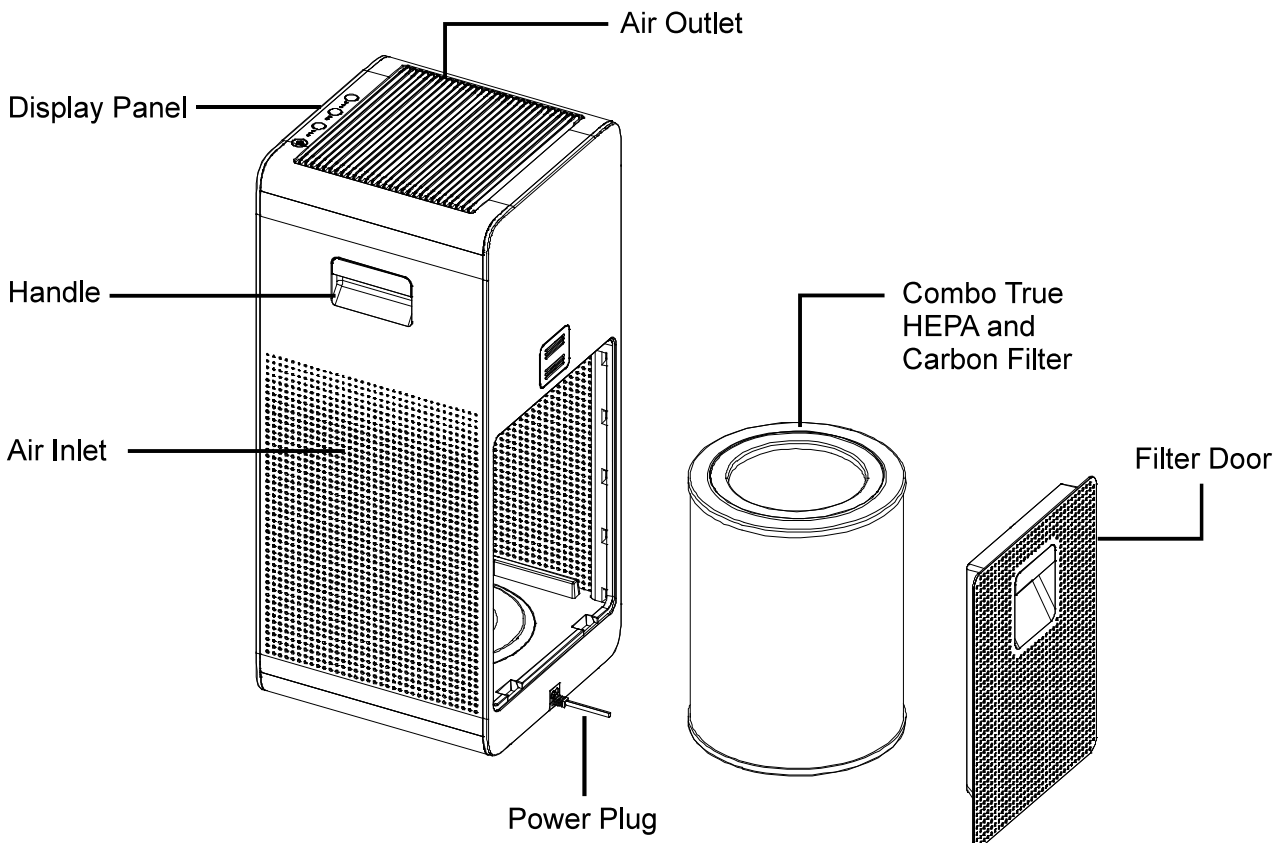

AIR PURIFIER SET-UP

NOTE: Follow these instructions for best results.

- Place unit at least ½ meter from the wall.
- Keep unit away from drafty areas.
- Keep curtains away from unit, as they may interfere with air intake/outlet.
- Place unit on a stable surface with plenty of air circulation.

1. Remove protective film from the control panel.

2. Open filter door.

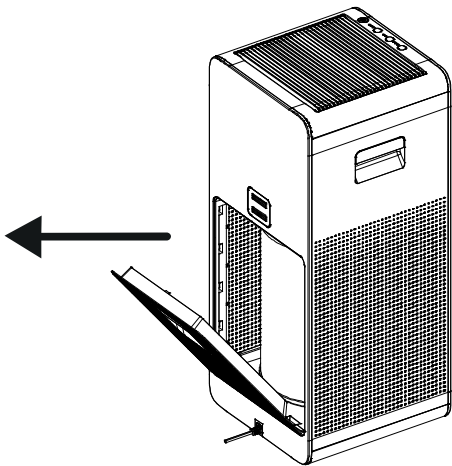

3. Take out filter and remove plastic filter bag.

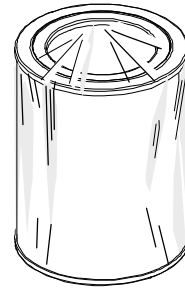

4. Place filter closed-side-down and press on plastic edges until fully seated back in the machine.

5. Close filter door securely.

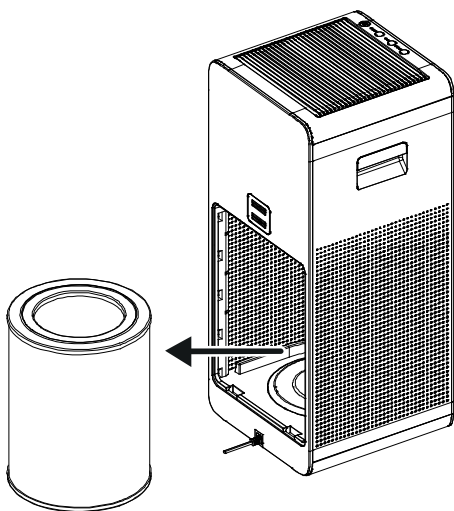
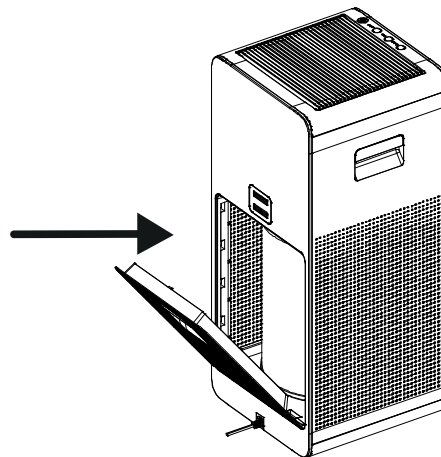

6. Plug in the power cord to a wall outlet.

7. Turn unit on. Unit will beep.

For approximately the first 4 minutes after turning the unit on, the auto icon will flash while the unit measures air quality.

DISPLAY PANEL

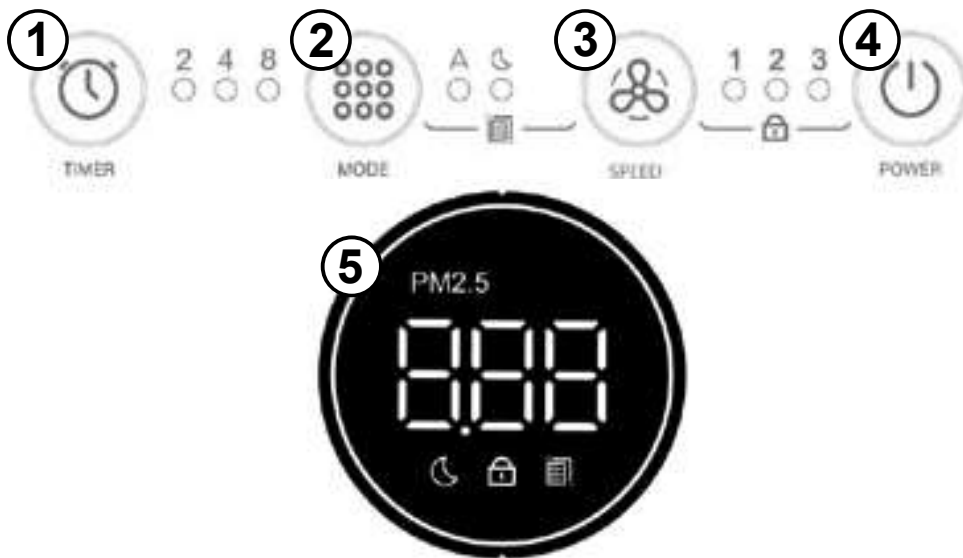

- 1. TIMER** - Press this button to select between timer settings. Timer can be set to turn the unit off in 2, 4 or 8-hours, indicated by the LED light. The timer can also be turned off by cycling past the 8-hour setting.
- 2. MODE** - Press this button to select between this unit's 3 operating modes:
 - Manual** - fan speed is controlled by the SPEED button. Neither of the MODE lights are lit.
 - Auto** - fan speed is automatically adjusted according to the air quality level. The "A" LED will be lit.
 - Sleep** - fan speed is set to low, the screen will go dark. The "SLEEP" LED will be dimly lit.
- 3. SPEED** - Press this button to select between this unit's 3 fan speeds.
- 4. POWER** - When unit is plugged in, the unit will automatically enter standby mode and the POWER button will be dimly lit.

Press this button when in standby mode to turn on the unit.

While powering up, the unit will beep once, the AUTO and SPEED 1 LED's will be lit. The green LED on screen will flash and show a 60 second countdown for particle sensor calibration. After the 60 seconds, the PM2.5 value on screen and the unit will enter AUTO mode.

While the unit is on, press this button to put the unit back into standby mode. The unit will beep once during this process.
- 5. FILTER REPLACEMENT REMINDER** - Once the filter has reached the end of its life, the AUTO and SLEEP LED's will flash to indicate it is time to replace the filter.

After replacing the filter, to reset the filter light, press down and hold the MODE and SPEED buttons at the same time for 5 seconds. The unit will beep once and the AUTO and SLEEP LED's will flash 3 times.
- 6. CHILD LOCK** - Press the SPEED and POWER buttons at the same time for 5 seconds to activate the child lock function. The machine will beep one time and the child lock symbol will appear on screen.

Other buttons will no longer work, and if pressed, will only flash the POWER LED 3 times.

To disable the child lock function, press SPEED and POWER buttons at the same time for 5 seconds. The unit will beep once and the child lock symbol will disappear.

OPERATION

AUTOMATIC OPERATION

The unit is set to default to automatic operation when it is first turned on. The air purifier will automatically sense the amount of impurities in the air, and adjust the fan speed to keep your air purified.

MANUAL OPERATION

After you turn on the unit, you can switch to manual operation by tapping the MODE button.

- **LOW, MEDIUM, OR HIGH SETTINGS**

These levels are recommended for standard daytime use. HIGH will activate automatically when sensors detect poor air quality.



AeraSmart™ SENSOR

Air quality indicator shows levels of air quality.



Green level indicates air is clean.

Amber level indicates air quality is poor.

Red level indicates high level of pollutants in the air.

CARE AND MAINTENANCE

CLEANING

- Clean unit as necessary by wiping with a dry, soft cloth; for stubborn stains, use a warm, damp cloth.
- Do not use volatile fluids such as benzene, paint thinner, or scouring powder, as they may damage the unit surface.
- Keep the unit dry.

Filter Replacement

The flashing AUTO and SLEEP LED's will signal when to replace the combination filter. The replacement period will vary depending on the hours of use and air quality. However, under normal usage, it will need to be replaced annually.

Do not wash and reuse the True HEPA or Carbon Filters—they will not work effectively. Only use Fellowes brand AeraMax™ replacement filters.



WARNING: Before replacing any filters, make sure to remove the power plug from the wall outlet.

Replacement Procedure

1. Open filter door.

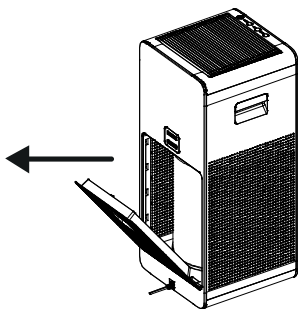

2. Remove and dispose of old filter.

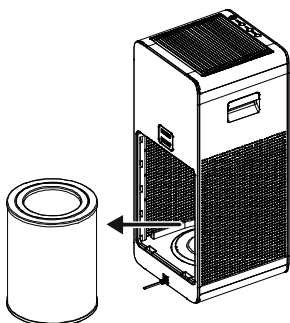

3. Remove any packaging wrap from the new filter(s).

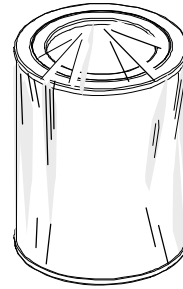

For replacement filter part numbers, see page 4.

4. Place the new filters in the main unit. (Closed side of the filter faces down). Press on plastic edges of the filter until firmly seated in the machine.
5. Close filter door securely.

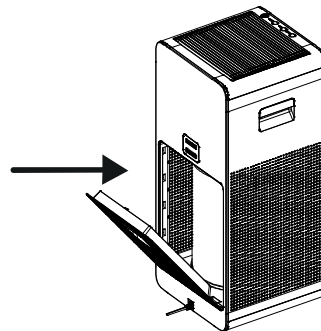

6. To reset the filter light once a new Filter is installed:
 - a. Be sure that drawer is closed.
 - b. Turn on the unit.
 - c. To reset the filter light, press the MODE and SPEED buttons at the same time for 3 seconds. This will turn off the lights and reset the filter life timer.

TROUBLESHOOTING

Before you call

Solutions to Common Problems

Review this list before you call for service. This list covers problems that are not the result of defective materials or workmanship.

PROBLEM	POSSIBLE SOLUTION
The unit leaves smoke and odors in the air.	<ul style="list-style-type: none"> • Make sure the sensor is not blocked or clogged. • Move the unit closer to the offending odors. • Replace the filters as needed.
The unit seems to produce odors.	<ul style="list-style-type: none"> • Replace the filters as needed.
The air quality control system fails to start.	<ul style="list-style-type: none"> • Check to assure unit is connected to power supply. • Make sure the filter door is closed completely. • make sure the unit is plugged in properly. • make sure the unit is on.
The unit interferes with radio or television reception.	<ul style="list-style-type: none"> • Because this unit radiates radio frequency energy, we suggest you try one or more of the following: <ul style="list-style-type: none"> - For better reception, adjust the television/radio antenna. - Move the unit away from the affected television/radio. - Plug the unit power cord into an outlet different from the television/radio power cord.
AUTO and SLEEP LED's continue to flash	<ul style="list-style-type: none"> • Repeat filter light reset instructions from page 8
Weak air output.	<ul style="list-style-type: none"> • Make sure plastic bag was removed from filter • Turn off machine and check that nothing is blocking the air outlet or intake