

Fellowes

AIR PURIFIERS

Array AW1/AeraMax Pro AM3/AM3 PC



INSTALLATION GUIDE GUIDE D'INSTALLATION GUÍA DE INSTALACIÓN

Please read instructions carefully before installing

Veuillez lire les instructions attentivement avant d'installer le produit

Lea cuidadosamente las instrucciones antes de instalar

KEY

- 1. Access panel
- 2. Filters
- 3. Filter frame
- 4. Main Assembly
- 5. Power Switch
- 6. Access panel latch
- 7. Access panel lock
- 8. Rear housing assembly
- 9. Control panel
- 10. Filter frame window

Fig 1

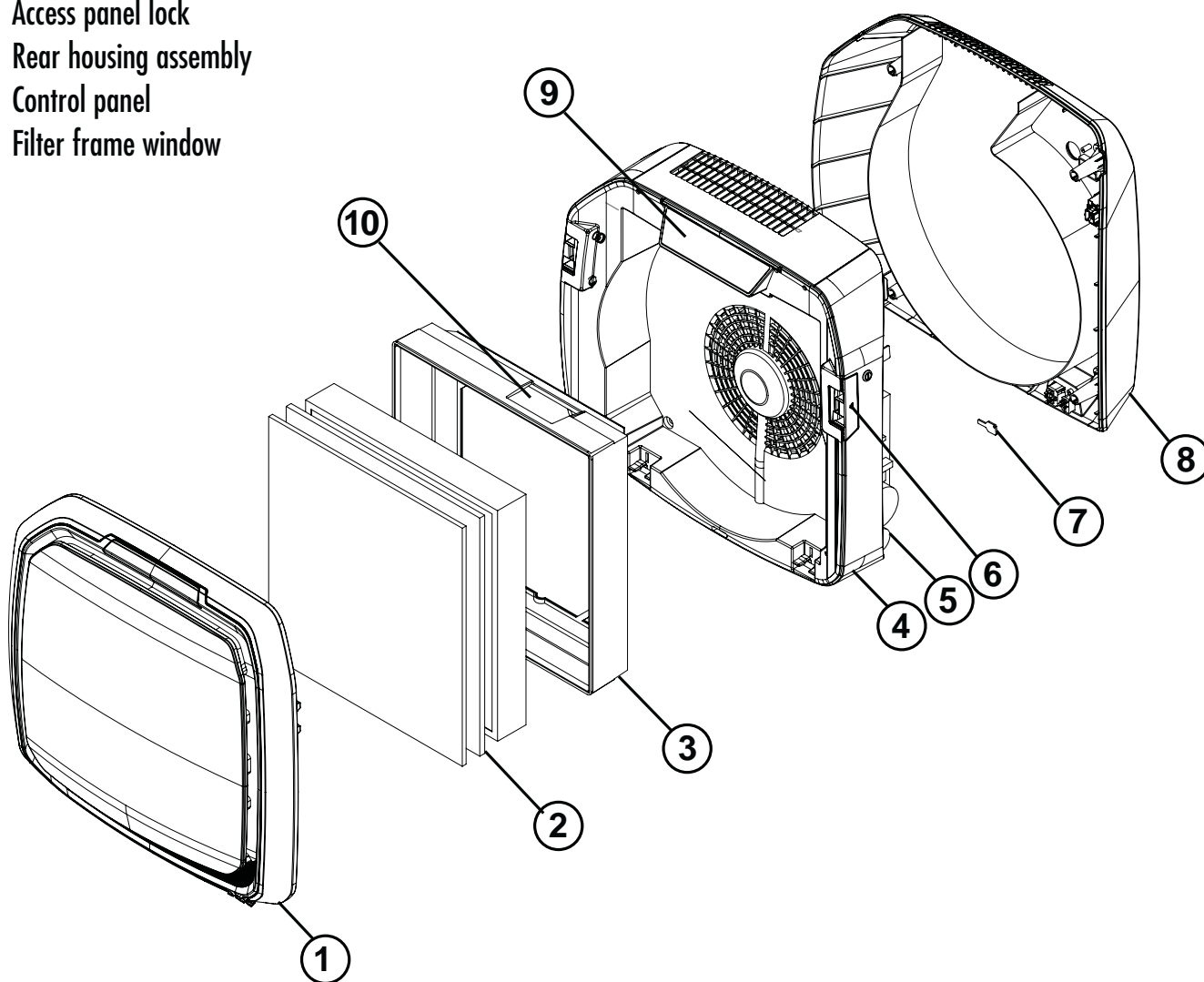

SAFETY

WARNING: To avoid the risk of electrocution confirm the electrical supply has been disconnected or switched off before beginning any installation work.

Confirm no electrical wiring, utility pipes, or duct work is located directly behind the installation / drilling area.

On a stud wall, it is strongly recommended at least 2 mounting anchors for the air purifier be mounted to an existing stud.

TOOLS REQUIRED FOR INSTALLATION

- Electric drill, drill bits (not included)
- # 2 Phillips and # 2 Flat Head stubby screw drivers (not included)
- Wire nuts (not included)
- Level (not included)
- Mounting template (included)

PARTS PROVIDED FOR INSTALLATION

- Drywall Anchors - 10mm OD
- Pan Head Phillips Screws

PRODUCT INSTALLATION GUIDELINES

Place the mounting template provided on the wall where the air purifier is to be installed. If air purifier is being mounted high on the wall make sure the top edge of the unit is positioned at least 8" inches (21 cm) below the ceiling to allow for filter replacement (see Fig 2).

Americans with Disabilities Act (ADA):

Be sure to follow all ADA guidelines pertaining to "Objects protruding into a circulation path." For more information visit www.ada.gov.

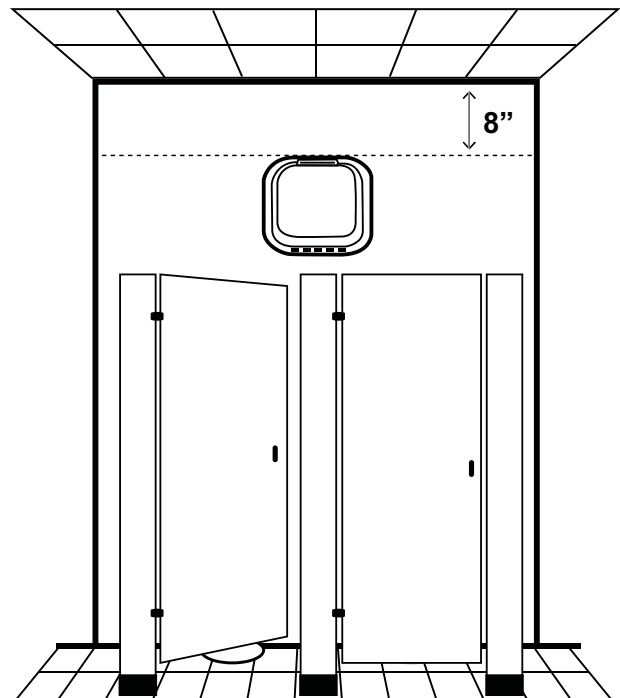
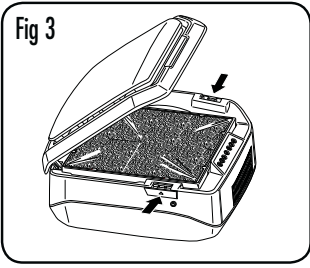

Fig 2

MOUNTING REAR HOUSING AND MAIN ASSEMBLY

Test the electrical outlet box first to ensure rated power requirements are met before beginning installation.

Remove air purifier from its shipping carton and remove all packing material.



Place the air purifier face up on a flat, stable work surface. Open the access panel by pressing in latches on each side of the unit (Fig 3).

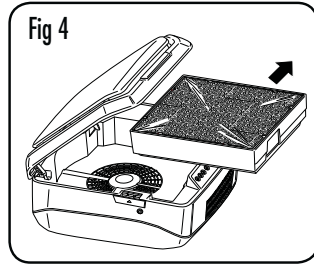

Open access panel and remove filter assembly by pulling out on top of side edges of frame, then lifting. NOTE: remove all plastic wrap from filters (Fig 4).

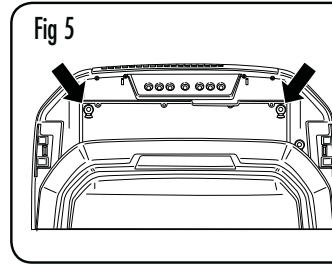
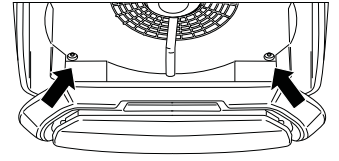
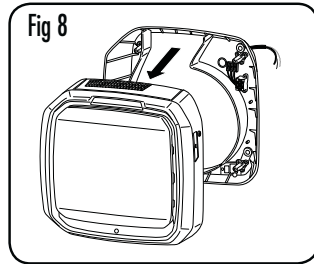
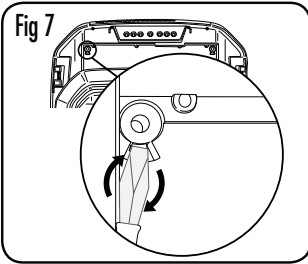

Fig 6



Remove the four housing screws (Fig 5 & 6) and set aside for re-assembly.



At the location of the two upper housing screws (Fig 5), insert a flat head screwdriver and gently twist to release tab as shown in Fig 7. This will disconnect main housing assembly from the rear housing assembly.

Disconnect main housing assembly from rear housing assembly. Separate main housing from rear housing. Lift main housing assembly away from rear mounting housing (Fig 8).

REAR HOUSING INSTALLATION & WIRING

Reference rear housing and locate desired mounting location. Again, it is strongly recommended at least 2 mounting anchors for the air purifier be mounted to an existing stud.

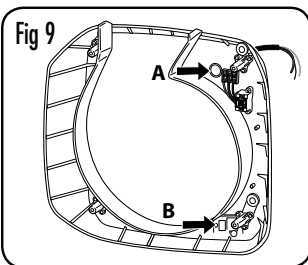

Using provided template ensure electrical outlet box is located behind cable hole (A) in Rear Housing assembly (Fig 9). Drill holes and place anchors in wall.

If mounting on concrete, cinder block or brick type walls route the wires through the "punch-out" hole marked (B) in Fig 9.

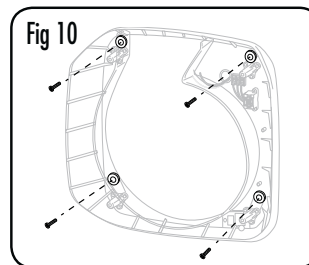

Check for washers at all mounting screw locations (Fig 10). Pull wires from electrical outlet box through hole in rear housing. Align housing over anchors and securely install all mounting screws.

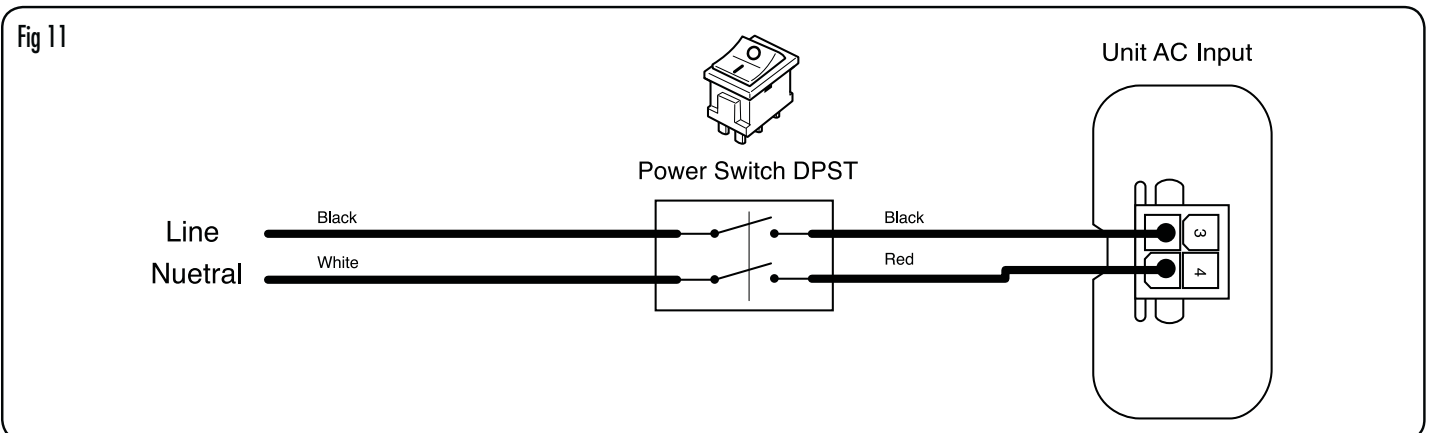

Attach wires from electrical outlet box to wires located inside rear housing using wire nuts. Match up line (black) and neutral (white) wires (Fig 11). Make sure all connections are made in accordance with federal, state and local codes and regulations.

MAIN ASSEMBLY INSTALLATION

WARNING: To avoid the risk of electrocution confirm the electrical supply has been disconnected or switched off before continuing any installation work.

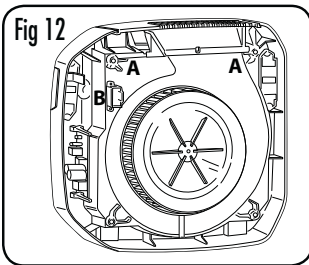

The power connector (B, in Fig 12) will carry power from the rear housing to the main housing once the assemblies are fully seated. The main assembly will attach to the rear housing assembly by the four screws previously removed (Fig 5 & 6). Two snap hooks (A, in Fig 12) will hold the main and rear assemblies together until the screws can be installed.

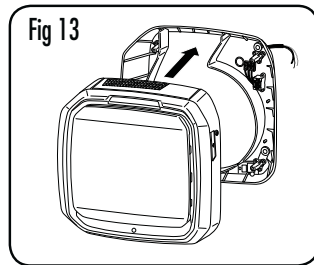

Carefully align the main assembly with the rear housing assembly. Slowly press into place until snap is heard, and there is no gap between the assemblies (Fig 13). The unit should now support its own weight.

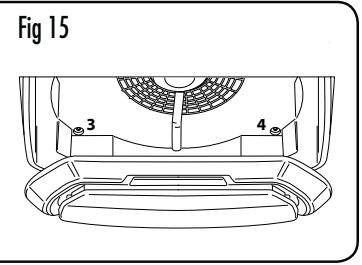
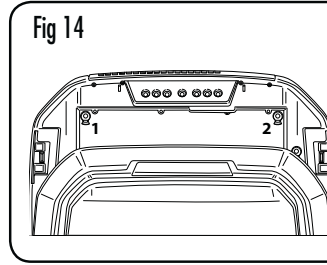

Install four screws (previously removed) to secure main assembly to rear housing assembly (Fig 14 & 15).

RE-INSTALLING FILTERS

IMPORTANT: Make sure all plastic wrap is removed from filters.

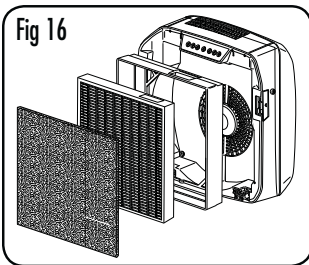

Make sure filters are in correct order - pre-filter / hybrid filter - and inserted into filter frame (Fig 16).

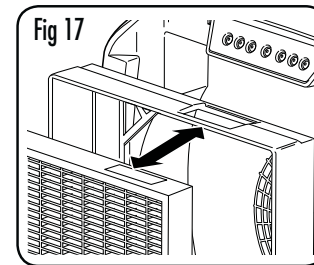

IMPORTANT: Make sure filter detection area aligns with window in filter frame (Fig 17).

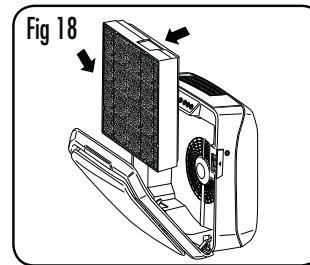

Open front panel by pressing latches on both sides of unit. Allow door to open fully. Insert filters – **IMPORTANT:** make sure filter detection window is aligned in upper right corner (Fig 18).

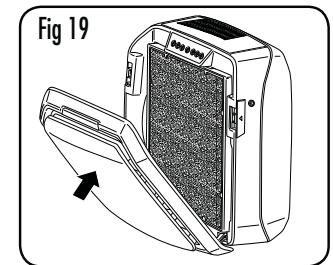

Close front panel by pressing firmly until both sides latch closed (Fig 19).

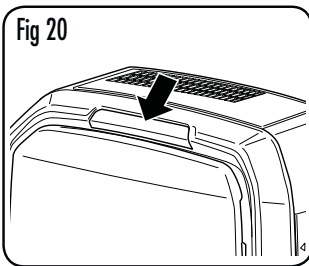

Once the unit is closed re-establish power. Lights on the control panel will be visible through the lens, indicating the unit is operational (Fig 20). The power light indicator will flash once a second.

LOCKING ACCESS PANEL

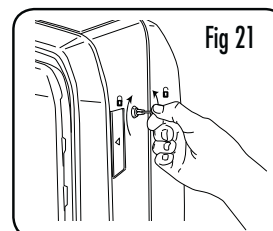

To restrict access to the control panel and filters the unit can be locked. To lock, insert the key provided and rotate clockwise $\frac{1}{4}$ turn (Fig 21).

Fellowes

AIR PURIFIERS

Array AW1

Wall Mounted Air Purifier
Purificateur d'air mural
Purificador de aire montado en la pared



PLEASE READ THESE INSTRUCTIONS BEFORE USE.
DO NOT DISCARD: KEEP FOR FUTURE REFERENCE.

VEUILLEZ LIRE CES INSTRUCTIONS AVANT D'UTILISER L'APPAREIL.
NE PAS JETER : CONSERVER AFIN DE CONSULTER LES DIRECTIVES
ULTÉRIEUREMENT, EN CAS DE BESOIN.

LEA ESTAS INSTRUCCIONES ANTES DEL USO.
NO LAS DESECHE: CONSÉRVELAS PARA REFERENCIA FUTURA.

*For a copy of the manual please visit www.fellowes.com

! WARNING: IMPORTANT SAFETY INSTRUCTIONS — Read Before Using!

PLEASE READ AND SAVE THESE INSTRUCTIONS. Read carefully before attempting to assemble, install, operate or maintain this product. Protect yourself and others by observing all safety information. Failure to comply with instructions could result in personal injury and/or property damage. Retain instructions for future reference.

IMPORTANT CAUTIONS AND INSTRUCTIONS FOR USING AIR PURIFIER:

WARNING – TO REDUCE THE RISK OF FIRE, ELECTRIC SHOCK, OR INJURY TO PERSONS, OBSERVE THE FOLLOWING:

- a) Use this unit only in the manner intended by the manufacturer. If you have questions, contact the manufacturer.
 - b) Before servicing or cleaning unit, switch power off at service panel and lock the service disconnecting means to prevent power from being switched on accidentally. When the service disconnecting means cannot be locked, securely fasten a prominent warning device, such as a tag, to the service panel.
- Do not use this air purifier as sole protection against harmful pollutants.
 - Do not repair or modify the unit unless specifically recommended in this manual. Only an authorized repair technician should disassemble, repair, or modify this product.
 - Installation work and electrical wiring must be done by qualified person(s). All electrical installation work must be conducted and carried out in accordance with all federal, state, and local codes and regulations.
 - Do not use if the power cord is damaged. If the power cord is damaged, it must be replaced by the manufacturer or a qualified technician.
 - Do not bend the power cable excessively or place heavy object on top of it.
 - When drilling into mounting surface, do not damage electrical wiring or other hidden utilities.
 - The product must be grounded.
 - Use only the electrical power (voltage and frequency) specified for the model air purifier being installed.
 - Do not obstruct the air inlet or air outlet of the air purifier.
 - Ensure filter bags are removed and filters are correctly installed before turning on. Do not operate this product without filters.
 - Do not wash and reuse any of the filters.
 - Do not use attachments or filters other than Fellowes brand, as unit will not function.
 - Do not spray aerosols on, or into the unit.
 - Do not use detergent to clean the unit.
 - Do not insert fingers, liquids, or foreign objects into the air intake or outlet.
 - Do not use the unit for anything other than air purification.
 - Do not install this product near heat-generating equipment.
 - This product will not remove carbon monoxide emitted from heating appliances or other sources.
 - Do not use the product near flammable substances or a gas leak.
 - Do not use the unit where it is humid or where the unit may get wet.
 - Do not alter the length of the power cord.
 - Not suitable for use with solid state speed controls.
 - This product is for indoor use only.
 - Change your filters at the recommended intervals to avoid particle and dust buildup.
 - This device contains licence-exempt transmitter(s)/receiver(s) that comply with Innovation, Science and Economic Development Canada's licence-exempt RSS(s). Operation is subject to the following two conditions:
 1. This device may not cause interference.
 2. This device must accept any interference, including interference that may cause undesired operation of the device
 - **! WARNING:** To reduce the risk of fire, electric shock, or injury to persons, do not use replacement parts that have not been recommended by the manufacturer (e.g. parts made at home using a 3D printer).

PRODUCT SPECIFICATIONS

Dimensions	19.5 X 21.0 X 9.5 in	495 X 533 X 241 mm
Weight of System	20.1 lbs	9.1 kg
Power Requirements	AC 120V 60Hz 1.8A	
Watts (5 fan speeds)	120W	

PACKAGING CONTENTS

- Air Purifier (1)
- 2-in-1 Hybrid Filter (1)
- Pre-Filter (1)
- Keys for Locking Front Panel (2)
- Registration information
- Quick Start Guide
- User Manual

DISPLAY PANEL

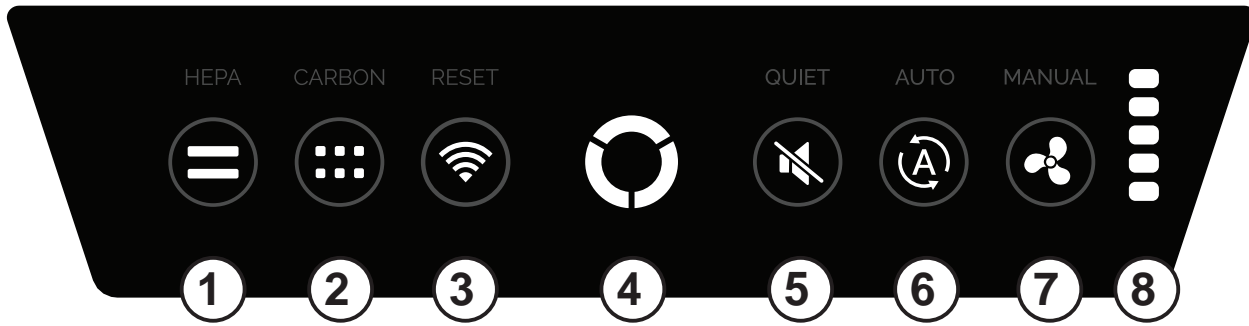

NOTE: after the unit is turned on the "AQ" light will flash for a few minutes while the system self-calibrates.

- 1 HEPA FILTER** – Press for 2s: reset the life counter of the HEPA filter.
Light (red): indicates filter life has reached 100%.
- 2 CARBON FILTER** – Press for 2s: reset the life counter of the carbon filter.
Light (red): indicates filter life has reached 100%.
- 3 WIRELESS STATUS/RESET** – Press for 10s: connection reset.
GREEN = Fully Connected & Paired
YELLOW = Connection Available
RED = Not Connected
RED (Blink) = Connection Error
BLUE = Reset Initialized
BLUE (Blink) = Reset Confirmed
OFF = Connection Disabled
- 4 AIR QUALITY INDICATOR** –
GREEN: sensors calibrating
BLUE: air quality Good
AMBER: air quality Fair
RED: air quality Poor
WHITE: door open
PURPLE: unit ping from cloud
- 5 QUIET** – Press: sets the unit to Quiet Mode.
Light: indicates unit is running in Quiet mode, where air quality sensor set fan speed automatically depending on environment with a max of fan speed 3.
- 6 AUTO** – Press: sets the unit to Auto mode.
Light: indicates unit is running in Auto mode where air quality sensors set fan speed automatically depending on environment.
- 7 MANUAL** – Press: cycle through fan speeds, a beep will be heard. If coming from Auto mode, will start at lowest fan speed.
Light: indicates fan speed is being controlled manually.
- 8 MANUAL INDICATORS** – Light: indicates which fan speed is currently selected in manual mode (1-5).

SCREEN CONTROLS

Screen					
Name	Home	Metric Detail	Filter Information	Screen Brightness	Turn Screen OFF
Functions	<p>Air Index AQI/Machine Status</p> <ul style="list-style-type: none"> Blue (Clean) <ul style="list-style-type: none"> o 91-100 Amber (Cleaning) <ul style="list-style-type: none"> o 81-90 Red (Cleaning) <ul style="list-style-type: none"> o 0-80 <p>Air Index Sensor Readings</p> <ul style="list-style-type: none"> Colors on next page 	<p>Air Index Sensor Readings</p> <ul style="list-style-type: none"> Blue <ul style="list-style-type: none"> o Ideal Amber <ul style="list-style-type: none"> o Acceptable Red <ul style="list-style-type: none"> o Raised Levels 	<p>Filter Identification</p> <p>Filter Life Remaining</p> <ul style="list-style-type: none"> Blue <ul style="list-style-type: none"> o 100-11% Amber <ul style="list-style-type: none"> o 1-10% Red <ul style="list-style-type: none"> o 0% <p>Replacement Filter Numbers</p>	Current Screen Brightness	Turn OFF Screen Option
Options Button	Go to 'Metric Detail' Page	Go to 'Home' Page	Toggle 'Front Page Notification'	Adjust Screen Brightness	Turn OFF Screen
Screen Button	Go to 'Filter Information' Page	Go to 'Filter Information' Page	Go to 'Screen Brightness' Page	Go to "Turn Screen OFF" Page	Go to 'Home' Page

FILTER CHANGE PROCEDURE

Unit will notify you when filter needs to be changed with a red light visible on the control panel. Always wear a mask and gloves when performing a filter change. For replacement filters, please visit www.fellowes.com

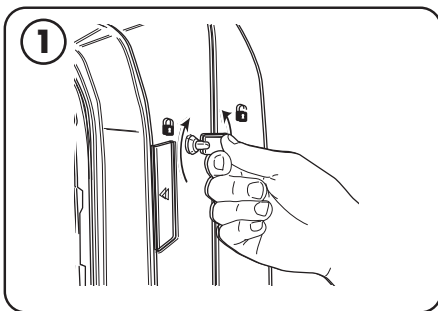

1. Unlock access panel: to unlock, insert the key provided and rotate counter-clockwise ¼ turn.

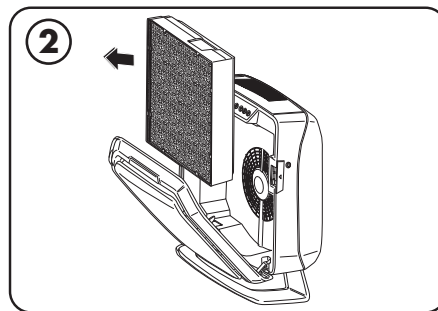

2. Open front access panel by pressing latches on both sides of unit. Allow panel to open fully. Remove filter(s) to be replaced.

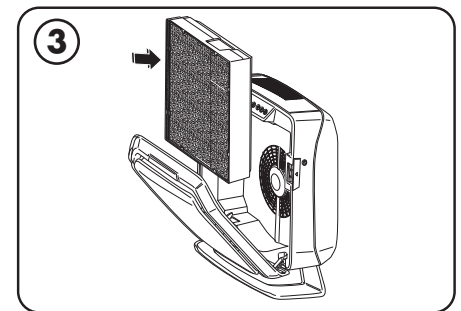

3. Remove any packaging wrap from the new filter(s) and re-install the filters.

FILTER RESET

When installing a new filter, the unit will automatically detect the filter type but the user will have to manually reset the filter replacement indicators with the following procedure:



Touch and hold the illuminated indicator for two seconds until a beep is heard and the indicator turns OFF.

WIRELESS CONNECTION – GETTING STARTED

This product has additional features that are only available when using the online dashboard.

To get started, please visit www.arrayviewpoint.fellowes.com

If you have questions or need help along the way, please contact us at 1-800-955-0959

MAINTENANCE AND CLEANING

Power down machine and remove filters before starting maintenance (See Filter Installation/Removal Guide).

Use dust cloth to remove dust and debris that may have built up around the unit internals.

Note: Do not attempt to clean inside fan blade area. Damage may occur to blades.

Note: Do not use the dust cloth to clean the filters.

If there is dust and debris near the exhaust areas of the unit, gently use a dust cloth to loosen the dust.

Once complete, reinstall the filters, turn the unit on, and close the door.

TROUBLESHOOTING

PROBLEM:	POSSIBLE SOLUTION:
The air quality control system fails to start.	<ul style="list-style-type: none">• Check to assure unit is connected to power supply.• Make sure filters are genuine filters, as unit will not function with other brands. IMPORTANT: Make sure filter detection area on genuine AeraMax® PRO replacement filter aligns with window in filter frame.• Review “Re-Installing Filters” section for further detail.• Make sure front access panel is closed completely.• Make sure power switch is on.
The Filter replacement indicator light remain lit after replacing the filter(s).	<ul style="list-style-type: none">• Repeat filter light reset instruction.

LIMITED WARRANTY

Limited Warranty: Fellowes, Inc. (“Fellowes”) warrants the Array AW1 Commercial Grade Air Purifier (“Product”) to be free from defects in material and workmanship for the time periods as set forth below.

The particle counters, IOT, sensors and display screen for a period of three (3) years from the date of original purchase of the Product.

All other parts for a period of five (5) years from the date of original purchase of the Product.

In the event that the Product is installed into new construction, the warranty period shall commence on the date of the occupancy permit or one year after the date of purchase, whichever is earlier. If any part is found to be defective during the warranty period, Fellowes will (at its sole option) either repair or replace the defective product with no charge for service or parts.

This warranty does not cover damage caused by use of non-Fellowes approved filters or failure to follow the recommended replacement schedule. This warranty does not apply in the cases of abuse, mishandling, failure to comply with product usage standards, operation using an improper power supply (other than listed on the label), installation error, or unauthorized repair. This warranty does not cover replaceable filters.

Fellowes reserves the right to charge the consumer for any additional cost occurred by Fellowes to provide parts or service outside of the country where the Product was initially sold by an authorized reseller. In the event that the Product is not readily accessible to Fellowes designated service personnel, Fellowes reserves the right to supply the customer with replacement parts or product in full satisfaction of its obligations under this warranty and any service obligations. **ANY IMPLIED WARRANTY, INCLUDING THAT OF MERCHANTABILITY OR FITNESS FOR A PARTICULAR PURPOSE, IS HEREBY LIMITED IN DURATION TO THE APPROPRIATE WARRANTY PERIOD SET FORTH ABOVE.** In no event shall Fellowes be liable for any consequential, incidental, indirect or special damages. This warranty gives you specific legal rights. The duration, terms, and conditions of this warranty are valid worldwide, except where different limitations, restrictions, or conditions may be required by local laws. For more details or to obtain service under this warranty, please contact us or your dealer.

INFORMATION TO THE USER

This equipment has been tested and found to comply with the limits for Class B digital device, pursuant to part 15 of the FCC Rules. These limits are designed to provide reasonable protection against harmful interference in an installation. This equipment generates, uses and can radiate radio frequency energy and, if not installed and used in accordance with the instructions, may cause harmful interference to radio communications. However, there is no guarantee that interference will not occur in a particular installation. If this equipment does cause harmful interference to radio or television reception, which can be determined by turning the equipment off and on, the user is encouraged to try to correct the interference by one or more of the following measures:

- Reorient or relocate the receiving antenna.
- Increase the separation between the equipment and receiver.
- Connect the equipment on a circuit different from that to which the receiver is connected.
- Consult the dealer or experienced radio/TV technician for help.