

AeraMax® Pro AM IVS and AM4S PC with Stand

AERA MAX® PROFESSIONAL

Air Purifier | Purificateur d'air | Purificador de aire | Luftreiniger
Purificatore d'aria | Luchtreiniger | Luftrenare | Luftrenser | Ilmanpuhdistin
Luftrenser | Oczyszczacz powietrza | Воздухоочиститель | Ιονιστής
Hava Filtresi | Čistička vzduchu | Čistič vzduchu | Légtisztító | Purificador de ar

CUSTOMER SERVICE & SUPPORT

www.fellowes.com

Europe Freephone: 00800-1810-1810
Benelux: +31-(0)-13-458-0580
Deutschland: +49 (0)511 545489-0
France: +33 (0) 1 78 64 91 00
Italia: +39-071-730041
Polska: +48 (22) 205-21-10
España/Portugal: +34-91-748-05-01
United Kingdom: +44 (0) 1302 836836

Declaration of Conformity

Fellowes Manufacturing Company

Unit 2 Ontario Drive, New Rossington, Doncaster, DN11 0BF, England

Declares that the product AeraMax® AMIVS and AM4S PC Pro conforms to the following requirements:
[2011/65/EU+2015/863/EU] Restriction of Hazardous Substances Directive [2004/108/EC] Electromagnetic Compatibility Directive
[2012/19/EU] Electrical Product Waste Reduction Human Exposure to Electromagnetic Fields
[2006/95/EC] Low Voltage Directive

To the following harmonized European Names [EN Standards] and IEC Standards.
EN 55014-1 EN 60335-2-65 EN 61000-3-3
EN 55014-2 EN 61000-3-2 EN 62233
EN 60335-1

And to the following standards:
PPP 76001:2008 incl. AIPS GS 2014:01 PAK
AS/NZS CISPR 14.1:2003
German Equipment and Product Safety Act Section 7 Subsection 1 Sentence 2 GPSG

Itasca, Illinois, USA
June 1, 2019

John Fellowes
President & CEO



Please read these instructions before use.
Do not discard: keep for future reference.

Lire ces instructions avant utilisation.
Ne pas jeter : conserver pour référence ultérieure.

Lea estas instrucciones antes de usarlo.
No las deseche: guárdelas para tenerlas como referencia.

Diese Anleitungen vor Gebrauch genau durchlesen.
Bitte nicht entsorgen: Zur späteren Bezugnahme aufheben.

Prima dell'uso, si raccomanda di leggere questo manuale di istruzioni.
Conservare il manuale per consultarlo secondo le necessità.

Deze instructies voor gebruik lezen.
Niet weggooien, maar bewaren om later te kunnen raadplegen.

Läs dessa anvisningar innan du använder apparaten.
Släng inte bort, behåll för framtida bruk.

Læs venligst denne vejledning før anvendelse.
Bør ikke bortskaffes. Behold for fremtidig henvisning.

Lue nämä ohjeet ennen käyttöä.
Älä hävittää: säilytä myöhempää käyttöä varten.

Vennligst les nøye igjennom denne bruksanvisningen før bruk.
Ikke kast den: Ta vare på den for senere referanse.

Przed użyciem proszę zapoznać się z tą instrukcją.
Nie wyrzucać - zachować jako źródło informacji na przyszłość

Перед началом эксплуатации обязательно прочтите данную инструкцию.
Не выбрасывайте данную инструкцию: сохраните ее для последующего использования.

Παρακαλείσθε να διαβάσετε αυτές τις οδηγίες πριν χρησιμοποιήσετε το προϊόν.
Μην τις απορρίψετε: κρατήστε τις για μελλοντική αναφορά.

Kullanmadan önce lütfen bu talimatları okuyun.
Atmayın: ileride başvurmak üzere saklayın.

Před použitím si přečtěte tyto pokyny.
Nelíkvídjte: uschovejte pro budoucí použití.

Pred použitím si prečítajte tieto pokyny.
Nezahadzujte: odložte pre budúce použitie.

Kérjük, hogy használat előtt olvassa el az utasításokat!
Az utasításokat ne dobja ki; tartsa meg referenciának-
yagként való jövőbeni használatra.

Leia estas instruções antes da utilização.
Não as deite fora: conserve-as para consulta futura.

Fellowes
Brands™

1789 Norwood Avenue, Itasca, Illinois 60143 • 1-800-955-0959 • www.fellowes.com

© 2019 Fellowes, Inc. | Part #411644

*For a copy of the manual please visit www.aeramaxpro.com

SAFETY INSTRUCTIONS/WARNING

Thank you for purchasing the AeraMax® PRO AM IVS.

Please read and save these instructions. Read carefully before attempting to assemble, install, operate or maintain this product. Protect yourself and others by observing all safety information. Failure to comply with instructions could result in personal injury and/or property damage. Retain instructions for future reference.

IMPORTANT CAUTIONS AND INSTRUCTIONS FOR USING AIR PURIFIER:

WARNING: Follow the instructions in this manual to reduce the risk of electric shock, short circuit, and/or fire:

- Do not use this air purifier as sole protection against harmful pollutants.
- Use this unit only in the manner intended by the manufacturer. If you have questions, contact the manufacturer.
- Do not repair or modify the unit unless specifically recommended in this manual. All repairs should be completed by a qualified technician.
- Use only permitted outside of Zone 2.
- The unit should be used with a residual current protective devices (RCDs) with a rated residual operating current not exceeding 30 mA.
- The plug for this unit is polarized with one blade wider than the other. Do not force the plug into an electrical outlet.
- Do not alter the plug in any way. If the plug does not fit into the outlet, reverse the plug. If it still does not fit, contact a qualified technician to install a proper outlet.
- Do not use if the power cord or plug is damaged or the connection to the wall outlet is loose.
- Do not damage, break, forcefully bend, pull, twist, bundle, coat, pinch, or place heavy objects on the power cord.
- Periodically remove dust from the power plug. This will reduce the chance that humidity will accumulate, which increases the risk of electric shock.
- If the power plug is damaged, it must be replaced by the manufacturer or a qualified technician.
- Remove the power plug from the outlet before cleaning the unit. When removing the power plug, grasp by holding the plug itself, never hold by the cord.
- Remove the power plug from the outlet when the unit is not in use.
- Do not handle the power plug with wet hands.
- Do not run power cord under carpets or cover with throw rugs.
- The AeraMax® PRO air quality control system must be grounded.
- Before servicing or cleaning the unit, switch power off at service panel. Lock service panel, or affix a warning tag, to prevent power from being switched back on accidentally.
- Use only the electrical power (voltage and frequency) specified for the model air purifier being installed.
- Do not obstruct the air inlet or air outlet of the air purifier.
- Do not use unit without filters installed.
- Do not wash and reuse any of the filters.
- Do not use attachments or filters other than AeraMax® PRO brand, as unit will not function.
- Do not spray aerosols on, or into the unit.
- Do not use detergent to clean the unit.
- Do not insert fingers, liquids, or foreign objects into the air intake or outlet.
- Do not use the unit for anything other than air purification.
- If the supply cord is damaged, it must be replaced by the manufacturer, its service agent or similarly qualified persons in order to avoid a hazard.
- This appliance can be used by children aged from 8 years and above and persons with reduced physical, sensory or mental capabilities or lack of experience and knowledge if they have been given supervision or instruction concerning use of the appliance in a safe way and understand the hazards involved. Children shall not play with the appliance. Cleaning and user maintenance shall not be made by children without supervision.

LIMITED PRODUCT WARRANTY

Limited Warranty: Fellowes, Inc. ("Fellowes") warrants the AeraMax® PRO air quality control system (the "Product") to be free of defects in material and workmanship for the time periods as set forth below.

- For PC units only: The particle counters and display screen for a period of three (3) years from the date of original purchase of the Product.
- For standard and PC units: All other parts for a period of five (5) years from the date of original purchase of the Product. In the event that the Product is installed into new construction, the warranty period shall commence on the date of the occupancy permit or one year after the date of purchase, whichever is earlier. If any part is found to be defective during the warranty period, your sole and exclusive remedy will be repair or replacement, at Fellowes' option and expense, of the defective part. This warranty does not cover damage caused by use of non-Fellowes approved filters or failure to follow the recommended replacement schedule. This warranty does not apply in cases of abuse, mishandling, failure to comply with product usage standards, operation using an improper power supply (other than listed on the label), or unauthorized repair. Fellowes reserves the right to charge the consumers for any additional costs incurred by Fellowes to provide parts or services outside of the country where the Product was initially sold by an authorized reseller. This warranty does not cover replaceable filters. In the event that the Product is not readily accessible to Fellowes designated service personnel, Fellowes reserves the right to supply customer with replacement parts or Product in full satisfaction of its obligations under this warranty and any service obligations. ANY IMPLIED WARRANTY, INCLUDING THAT OF MERCHANTABILITY OR FITNESS FOR A PARTICULAR PURPOSE, IS HEREBY LIMITED IN DURATION TO THE APPROPRIATE WARRANTY PERIOD SET FORTH ABOVE. In no event shall Fellowes be liable for any consequential, incidental, indirect or special damages. This warranty gives you specific legal rights. The duration, terms, and conditions of this warranty are valid worldwide, except where different limitations, restrictions, or conditions may be required by local laws.

PACKAGING CONTENTS

- AeraMax® PRO Air Quality Control System
- True HEPA Filter with AeraSafe™ Antimicrobial Treatment (2 filters)
- Activated Carbon Filter w/Pre-Filter (2 of each filter)
- Keys for Locking Front Panel (2)
- Registration information

PRODUCT SPECIFICATIONS

AeraMax® PRO AM IVS	
Dimensions (H x W x D)	49.7 x 88.1 x 22.8 cm
Weight of System (including filters)	15.1 kg
Power Requirements	220-240V, 50/60Hz, 1.4A
Power Consumption (5 fan speeds)	8, 12, 18, 35, 180 watt
Air Delivery (5 fan speeds)	260, 316, 381, 476, 748 CFM
Decibels	42, 44, 51, 53, 68 dB
Display	Capacitive Touch, Internal Access Only
Sensors	EnviroSmart™
Sensor Controlled Operation Modes	2 Primary modes - Normal Mode and Quiet Mode
Supplied Filters	2 True HEPA Filters with AeraSafe™ Antimicrobial Treatment with an estimated average filter life of 1 year, 2 Activated Carbon Filters with Pre-Filter, estimated average filter life 6 months.
Cleaning System	High Efficiency Particulate Air (HEPA) filter rated efficiency of 99.97% of airborne particulate at 0.3 microns. Carbon Filter adsorbs odor and volatile organic compounds, PlasmaTRUE™ bipolar ionizer.

REPLACEMENT FILTERS

2" HEPA	True HEPA filter replacement with AeraSafe™ treatment. Average filter life 12 - 18 months: 9416602 - 2 pack
3/8" Carbon	Granular activated carbon replacement filter with pre-filter. Average filter life 6 months: 9416502 - 4 pack
2" Carbon	Granular activated carbon replacement filter. Average filter life 2 years: 9436802 - 2 pack
2" Hybrid 1"	True HEPA and 1" Carbon with pre-filter hybrid replacement filter. Average filter life 1 year: 9436902 - 2 pack

For additional replacement filter and accessory information please visit: www.aeramaxpro.com

INFORMATION TO THE USER

This equipment has been tested and found to comply with the limits for Class B digital device, pursuant to part 15 of the FCC Rules. These limits are designed to provide reasonable protection against harmful interference in an installation. This equipment generates, uses and can radiate radio frequency energy and, if not installed and used in accordance with the instructions, may cause harmful interference to radio communications. However, there is no guarantee that interference will not occur in a particular installation. If this equipment does cause harmful interference to radio or television reception, which can be determined by turning the equipment off and on, the user is encouraged to try to correct the interference by one or more of the following measures:

- Reorient or relocate the receiving antenna
- Increase the separation between the equipment and receiver
- Connect the equipment on a circuit different from that to which the receiver is connected.
- Consult the dealer or experienced radio/TV technician for help.

WARNING: Any changes or modifications not expressly approved by the manufacturer could void the user's authority to operate the equipment and warranty.

DISPLAY PANEL

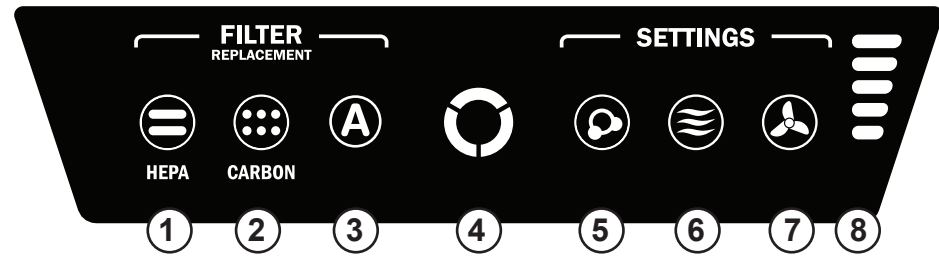

NOTE: after the unit is turned on the "AQ" light will flash for a few minutes while the system self-calibrates.

- 1 **HEPA FILTER REPLACEMENT INDICATOR** — This indicator will show its status when the access panel is open or closed. If the light is red this indicates the filter needs replacing. The replacement period will vary depending on the filters used, hours of use, air quality, and rate of air flow. For filter replacement indicator descriptions see *FILTER REPLACEMENT INDICATORS* section.
- 2 **CARBON FILTER REPLACEMENT INDICATOR** — This indicator will show its status when the access panel is open or closed. If the light is red this indicates the filter needs replacing. The replacement period will vary depending on the filters used, hours of use, air quality, and rate of air flow. For filter replacement indicator descriptions see *FILTER REPLACEMENT INDICATORS* section.
- 3 **ACCESSORY INDICATOR** — This indicator will show its status when the access panel is open or closed. This indicator will only be used if an accessory filter is installed in the unit. If the light is red this indicates the filter needs replacing. The replacement period will vary depending on the filters used, hours of use, air quality, and rate of air flow. For filter replacement indicator descriptions see *FILTER REPLACEMENT INDICATORS* section.
- 4 **AIR QUALITY SENSOR** — This indicator will show its status when the access panel is open or closed. This indicator monitors the air quality and adjusts the fan speed to keep your air purified. Blue, amber, and red lights indicate the purity of your air.
- 5 **PlasmaTRUE™ TECHNOLOGY** — This indicator will show its status when the access panel is open or closed. Creates an ionized field to help safely remove airborne pollutants. To turn on and off the PlasmaTRUE™ TECHNOLOGY, touch and hold the PLASMA indicator. A blue light illuminates when the PlasmaTRUE™ TECHNOLOGY is enabled. To disable the PlasmaTRUE™ TECHNOLOGY, press and hold "Plasma" indicator until light is off.
- 6 **AUTO MODE** — To select, press and hold the button until the icon illuminates. This mode uses the EnviroSmart™ technology to monitor the air quality, motion and noise level to adjust the fan speed in order to purify your air as quickly as possible. This button also includes QUIET MODE. To select, press and hold until the button turns purple. The machine will continue to use EnviroSmart™ but only utilizes the 3 lowest, most quiet of the 5 fan speeds.
- 7 **MANUAL MODE** — To select, press the button until the icon illuminates. This mode allows you to choose one of the 5 fan speeds and keep the unit at this speed until AUTO MODE is chosen again. The internal sensors will not adjust the fan speed in this mode.
- 8 **FAN SPEED INDICATORS** — The fan has 5 speeds and can reach turbo speed to clean the room in case of high levels of contaminants. The number of bars illuminated indicates fan speed.

1 – whisper	4 – high
2 – low	5 – turbo
3 – medium	

OPERATION

The air purifier continuously works in automatic mode; the user can select which preference they would like the purifier to use based on the location or desired operation of the air purifier. The purifier will operate through a minimized range of speeds, not exceeding the maximum level selected, in order to run quietly while cleaning the room of contaminants. Once air is cleaned, and no sensors are activated, the unit lowers to energy saving mode to reduce energy consumption and extend the life of the filters.

When Auto Mode is selected, the Auto mode indicator will be blue. This mode uses the EnviroSmart™ technology to monitor the air quality, motion and noise level to adjust the fan speed in order to purify your air as quickly as possible. Once air is cleaned, and no sensors are activated, the unit lowers to energy saving mode to reduce energy consumption and extend the life of the filters.

The machine will continue to use EnviroSmart™ but only utilizes the 3 lowest, most quiet of the 5 fan speeds.

When Manual Mode is selected, the Manual mode indicator will be blue. This mode allows you to choose one of the 5 fan speeds and keep unit at this speed until Auto Mode is chosen/selected. EnviroSmart™ sensors will NOT adjust the fan speed in this mode.

SET UP

1. Open unit by pressing the latches on both sides.
2. Remove bag(s) from filter(s) and place back in the unit.
3. Plug the IEC plug into the power cord socket on the back of the unit.

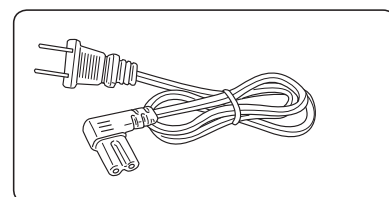

CARE AND MAINTENANCE

CLEANING:

- Clean external housing as necessary by wiping with a dry, soft cloth; for stains, use a warm, damp cloth.
- Do not use volatile fluids such as benzene, paint thinner, scouring powder or other cleaners that may damage the unit surface.
- Clean intake and exhaust vents by wiping with a dry, soft cloth.

FILTER REPLACEMENT INDICATORS:

The replacement filter indicators will signal when to replace the HEPA Filter and/or Carbon with Pre-Filter. The replacement period will vary depending on the hours of use, air quality, and rate of air flow. However, under normal usage, most HEPA Filters need to be replaced every 2 years, and Carbon with Pre-Filter every 6 months. When a filter needs to be replaced the following color will be shown on any one of the HEPA, CARBON, or ACCESSORY filter replacement indicators:

- Red Flashing = RIGHT filter 90% full
- Amber Flashing = LEFT filter 90% full
- Red Flash, Pause, Amber Flash, Pause = Right & LEFT filters 90% full
- Red = Replace RIGHT filter
- Amber = Replace LEFT filter
- Red & Amber Alternating = Replace Right & Left filters

Do not wash and reuse any of the filters – they will not work effectively. Only use AeraMax® PRO brand replacement filters as units will not function using any other replacements.

FILTER REPLACEMENT PROCEDURE:

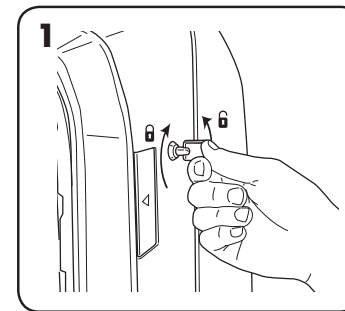

Unlock access panel: to unlock, insert the key provided and rotate counter-clockwise ¼ turn.

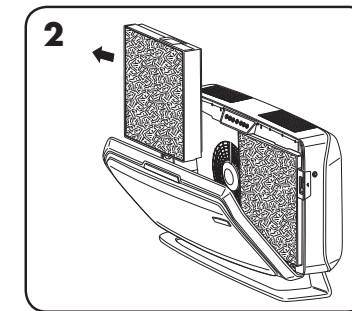

Open front access panel by pressing latches on both sides of unit. Allow panel to open fully. Remove filter(s) to be replaced.

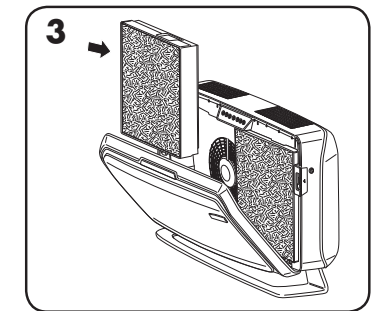

Remove any packaging wrap from the new filter(s) and re-install the filters.

FILTER REPLACEMENT:

When installing a new filter the unit will automatically detect the filter type but the user will have to manually reset the filter replacement indicators. To reset the flashing filter replacement indicator use the following procedure:

- 1 Touch and hold the illuminated indicator for three seconds until a beep is heard and the indicator is flashing green.
- 2 Release finger from indicator.
- 3 Touch and hold the indicator for three seconds until a beep is heard and the indicator light turns off.

Note: If you do not complete step three within 10 seconds of completing step 1 then the indicator light will not be reset.

TROUBLESHOOTING

PROBLEM:	POSSIBLE SOLUTION:
The air quality control system fails to start.	<ul style="list-style-type: none"> • Check to assure unit is connected to power supply. • Make sure filters are genuine AeraMax® PRO filters, as unit will not function with other brands. IMPORTANT: Make sure filter detection area on genuine AeraMax® PRO replacement filter aligns with window in filter frame. • Review "Re-Installing Filters" section for further detail. • Make sure front access panel is closed completely. • Make sure power switch is on.
The unit makes a faint ticking sound.	<ul style="list-style-type: none"> • This indicates that the "PlasmaTRUE™" bipolar ionizer is working.
The HEPA and/or Carbon Filter replacement indicator light remain lit after replacing the filter(s).	<ul style="list-style-type: none"> • Repeat filter light reset instruction.

AERA MAX[®]

PROFESSIONAL

Air Purifier with Particle Counters
For use with machines AM3 PC,
AM3S PC, AM4 PC & AM 4S PC

Luftrenser med Partikkeltellere
Til bruk med maskinene AM3 PC,
AM3S PC, AM4 PC & AM 4S PC

Purificateur d'air avec compteurs
de particules
Pour les machines AM3 PC, AM3S
PC, AM4 PC et AM 4S PC

Oczyszczacz powietrza z licznikami cząstek
Do użytku z urządzeniami AM3 PC,
AM3S PC, AM4 PC oraz AM 4S PC

Purificador de aire con medidor
de partículas
Para su uso con máquinas AM3 PC,
AM3S PC, AM4 PC y AM 4S PC

Воздухоочиститель со счетчиками частиц
Для машин AM3 PC, AM3S
PC, AM4 PC и AM 4S PC

Luftreiniger mit Partikelzählern
Zur Verwendung mit den Geräten AM3
PC, AM3S PC, AM4 PC und AM 4S PC

Ιονιστής με μετρητές σωματιδίων
Για χρήση με τα μηχανήματα AM3
PC, AM3S PC, AM4 PC & AM 4S PC

Purificatore d'aria con contatori
di particelle
Per l'uso con apparecchi AM3 PC,
AM3S PC, AM4 PC e AM 4S PC

Partikül Sayaçlı Hava Arıtıcısı
Kullanıldığı makineler: AM3 PC,
AM3S PC, AM4 PC ve AM 4S PC

Luchtreiniger met deeltjestellers
Voor gebruik met apparaten AM3
PC, AM3S PC, AM4 PC & AM 4S PC

Čistička vzduchu s počítadlem částic
Pro použití u zařízení AM3 PC,
AM3S PC, AM4 PC a AM 4S PC

Luftrenare med partikelräknare
För användning tillsammans
med maskinerna AM3 PC, AM3S
PC, AM4 PC och AM 4S PC

Čistička vzduchu s počítadlom částic
Na použitie spolu so zariadeniami AM3
PC, AM3S PC, AM4 PC a AM 4S PC

Luftrenser med partikeltællere
Til brug med maskinerne AM3 PC,
AM3S PC, AM4 PC & AM 4S PC

Légtisztító részecskeszámlálókkal
AM3 PC, AM3S PC, AM4 PC és AM 4S
PC berendezéssel való használatához

Purificador de ar com contadores
de partículas
Para utilizar com as máquinas AM3
PC, AM3S PC, AM4 PC e AM 4S PC

Ilmanpuhdistin, jossa on hiukkaslaskin
Käytettäväksi seuraavissa laitteissa:
AM3 PC, AM3S PC, AM4 PC & AM 4S PC

Thank you for purchasing the AeraMax[®] Professional with particle counters.
Please read and save these instructions.



This AeraMax[®] unit uses its advanced and patented EnviroSmart[™] 2.0 Technology to measure air particles and adjust the machine speed as needed. Unit utilizes particle counters, VOC, audio and motion sensors to effectively clean your environment.

TO CHANGE MODES or SCREENS

To access different air quality modes, push the top **MODE** button.

To change between the screens, push the bottom **PAGE** button.



MODE

Controls functionality within each **PAGE**



PAGE

Cycles Page

**2 Cap-Touch
Buttons**





Out

This number is the amount of air particles detected in the filtered air exiting the air purifier.

In

This number is the amount of air particles coming into the unit from the ambient air. These have not been directly filtered yet.

1. This screen displays a total snapshot of your room air quality.

The top section of the screen gives you a graphical representation of your current room air quality. The graphical display is based on the PM2.5 IN readings (from the PM2.5 screen) of the room's air that is entering the unit.

Room Air Quality:

If $PM_{2.5} = 0 - 12 \mu\text{g}/\text{m}^3$, it will display "CLEAN" inside of a blue graphic.

If $PM_{2.5} = 12.1 - 35.4 \mu\text{g}/\text{m}^3$, it will display "CLEANING" inside of a yellow graphic.

If $PM_{2.5} = 35.5+ \mu\text{g}/\text{m}^3$, it will display "CLEANING" inside of a red graphic.

The middle section of the screen displays the current cleaning efficiency which calculates the percentage reduction of PM2.5 particulate matter coming out of the purifier vs. PM2.5 particulate matter coming in. The PM2.5 readings refer to atmospheric particulate matter that have a diameter of 2.5 μm and smaller (example viruses, bacteria and smoke).

2. **PM2.5** - Displays particle density ($\mu\text{g}/\text{m}^3$ or mass per volume) of particle sizes 2.5 μm and smaller (example viruses, bacteria and smoke). This air quality status displayed is related to the United States EPA's AQI (Air Quality Index). For more information, please visit <http://www.airnow.gov>.

If the particle reading is between 0 – 12, it displays a CLEAN measurement in blue.

If the particle reading is between 12.1 – 35.4, then it displays a FAIR measurement in yellow.

If the particle reading is 35.5+ or more, then it displays a POOR measurement in red.

3. **PM10** - Displays particle density ($\mu\text{g}/\text{m}^3$ or mass per volume) of particles sizes 10 μm and smaller (for example pollen, dust, smoke, allergens and viruses). The air quality status displayed is related to the United States EPA's AQI (Air Quality Index). For more information, please visit <http://www.airnow.gov>.

If the particle reading is between 0 – 54, it displays a CLEAN measurement in blue.

If the particle reading is between 55 – 154, then it displays a FAIR measurement in yellow.

If the particle reading is 155+ or more, then it displays a POOR measurement in red.

ODOR/VOC



This measures the level of VOC's (volatile organic compounds) and odors coming into the unit from the ambient air. This has not been directly filtered yet. The machine adjusts its performance based on VOC's detected.

Blue - low level of VOC's detected

Yellow - medium level of VOC's detected

Red - high level of VOC's detected

CARBON ONLY FILTERS

It is NOT recommended to use carbon only filters with the AM3 PC, AM3S PC, AM4 PC, or AM4S PC units. Carbon filters do not capture particle sizes that can be detected by our sensors. In the case that a carbon only filter is used, the display changes to display VOC / ODOR LEVEL only. This will show the status similar to the VOC / ODOR bar with LOW / BLUE, MEDIUM / YELLOW, HIGH / RED. This screen automatically displays when the unit detects a carbon only filter, and cannot be selected.



FILTER INFORMATION

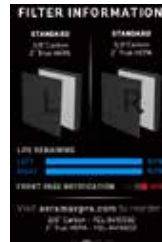

This screen contains the information needed to manage and reorder filters. The image(s) shown is the current filter inside the unit. AM3 will show 1 filter configuration while AM4 will show 2 filter configurations.

Life Remaining measures the estimated amount of life remaining in the HEPA and/or Carbon filter(s). AM3 will have 1 countdown while AM4 will have one for the left and right filters. To keep machine performing optimally, replace the filters once this percentage reaches 10% - 0% and the front screen flashes a "reorder filter" or "replace filter" alert.

See the Machine Manual to reset filters on the machine's user interface.

These alerts will automatically turn off once the filter is replaced/reset or you can turn this alert off at any time by pressing the MODE button to change FRONT PAGE NOTIFICATION to off. Once the new filters are replaced/reset, the life countdown will restart automatically.

These alerts will display for 5 seconds and replace the OUT readings once every 1 minute until reset or shut off.



Item number(s) are included to reorder replacement filter(s) on the website aeramaxpro.com.

If this page is left on with no activity, it will automatically return back to the main page after 5 minutes.

BRIGHTNESS

GENERAL PAGE

Push the MODE button while on this screen to increase/decrease the brightness of the display. If this page is left on with no activity, it will automatically return back to the main page after 1 minute.

If for any reason you'd like to have the screen on, but not display the particle or VOC readings, you can push the PAGE button to display the EnviroSmart 2.0 page.

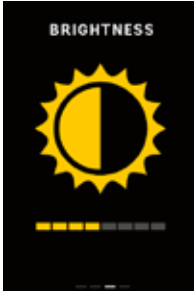

SCREEN ON/OFF

TURN OFF SCREEN: If you would like to turn the screen off, push the PAGE button until the screen appears. Once on that page, press MODE button to confirm and shut off or PAGE button to cancel.

TURN SCREEN BACK ON: Pressing and holding either of these buttons for 3 seconds will turn the screen back on.



Auto Sleep Mode - The screen will automatically go into sleep mode/off if no audio or motion is detected. To wake up the screen, wave hand near unit or press one of the side buttons.