

**Fellowes**

WORK BETTER™

Powershred® 425Ci/425i/485Ci/485i  
The World's Toughest Shredders™  
Factory Service



CUSTOMER SERVICE & SUPPORT

[www.fellowes.com](http://www.fellowes.com)

United States: 1-800-955-0959

Canada: 1-800-665-4339

Mexico: 001-800-514-9057



**Fellowes**  
Brands™







1789 Norwood Avenue, Itasca, Illinois 60143 • 1-800-955-0959 • [www.fellowes.com](http://www.fellowes.com)

© 2016 Fellowes, Inc. | Part #409954

PLEASE READ THESE INSTRUCTIONS BEFORE USE.  
DO NOT DISCARD: KEEP FOR FUTURE REFERENCE.



## TROUBLESHOOTING

-  **Low Oil Indicator:** When illuminated, the shredder is out of oil and needs to be refilled. See the Product Maintenance section for refill instructions. For optimum performance, use Fellowes oil (35250). \*Auto Oil™ is only featured on cross cut models – 425Ci and 485Ci.
-  **Bin Full Indicator:** When illuminated, the shredder waste bin is full and needs to be emptied. Use Fellowes waste bag 3605801.
-  **SafeSense® Indicator:** If hands are too close to the paper entry, the SafeSense® indicator will illuminate and the shredder will stop shredding. If SafeSense® is active for 3 seconds, the shredder will automatically turn off and the user must press the power button on the control panel to resume shredding.
-  **Remove Paper Indicator:** When illuminated, press reverse (←) and remove paper. Reduce paper quantity to an acceptable amount and refeed into paper entry.
-  **Door Open Indicator:** The shredder will not run if the cabinet door is open. When illuminated, close the door to resume shredding.
-  **Straight Feed Indicator:** When illuminated, remove paper and feed straight into paper entry.

## 100% JAM PROOF SYSTEM OPERATION\*

**JAM PROOF** Eliminates paper jams and powers through tough jobs.

### DISABLING THE FEATURE

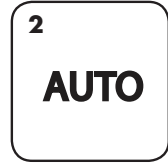
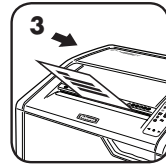
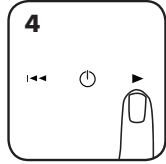
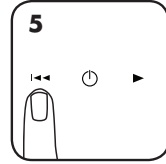
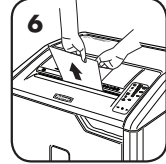
-  **1**  
Should you choose to disable the system, press and hold the auto and reverse (←) buttons at the same time
-  **2**  
Once disabled, the blue Auto light is no longer illuminated (To re-engage, repeat step 1)
-  **3**  
Shredding can continue with the system disabled; however, a paper jam may occur with too many sheets and Remove Paper icon (🏠) will illuminate
-  **4**  
If jam occurs, press and hold forward (▶) button until the document is completely through the shredder
-  **5**  
If not cleared, press reverse (←) briefly (repeat steps 4 and 5 until shredded)
-  **6**  
If steps 4 and 5 do not clear jam, reverse paper all the way out, remove several sheets and refeed

\*100% Jam Proof when used in accordance with user manual

## LIMITED PRODUCT WARRANTY

Limited Warranty: Fellowes, Inc. ("Fellowes") warrants the parts of the machine to be free of defects in material and workmanship and provides service and support for 1 year from the date of purchase by the original consumer. Fellowes warrants the cutting blades of the machine to be free from defects in material and workmanship for 1 year from the date of purchase by the original consumer. If any part is found to be defective during the warranty period, your sole and exclusive remedy will be repair or replacement, at Fellowes' option and expense, of the defective part. This warranty does not apply in cases of abuse, mishandling, failure to comply with product usage standards, shredder operation using an improper power supply (other than listed on the label), or unauthorized repair. Fellowes reserves the right to

charge the consumers for any additional costs incurred by Fellowes to provide parts or services outside of the country where the shredder is initially sold by an authorized reseller. ANY IMPLIED WARRANTY, INCLUDING THAT OF MERCHANTABILITY OR FITNESS FOR A PARTICULAR PURPOSE, IS HEREBY LIMITED IN DURATION TO THE APPROPRIATE WARRANTY PERIOD SET FORTH ABOVE. In no event shall Fellowes be liable for any consequential or incidental damages attributable to this product. This warranty gives you specific legal rights. The duration, terms, and conditions of this warranty are valid worldwide, except where different limitations, restrictions, or conditions may be required by local law. For more details or to obtain service under this warranty, please contact us or your dealer.

## ENGLISH

Models 425Ci/425i/485Ci/485i

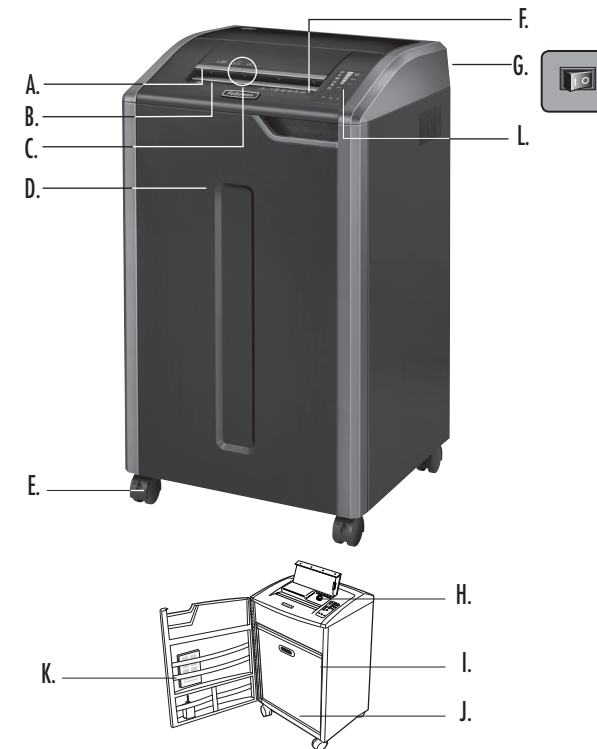

### KEY

- |   |   |
|---|---|
| A. SafeSense® Technology                        | J. Basket                                       |
| B. Paper entry                                  | K. Accessory tray                               |
| C. CD, credit card and junk mail entry          | L. Control panel                                |
| D. Door   | 1. Sheet capacity indicator                     |
| E. Casters                                      | 2. Low oil indicator (red) 425Ci and 485Ci only |
| F. See safety instructions                      | 3. Bin full (red)                               |
| G. Disconnect power switch                      | 4. SafeSense® (yellow)                          |
| ○ 1. OFF  | 5. Remove paper (red)                           |
| ◻ 2. ON   | 6. Door open (red)                              |
| H. Oil reservoir 425Ci and 485Ci only           | 7. Straight feed (red)                          |
| I. Oil drain plug (inside) 425Ci and 485Ci only | 8. Auto button                                  |
|   | 9. Reverse                                      |
|   | 10. ON/OFF (blue)                               |
|   | 11. Forward                                     |

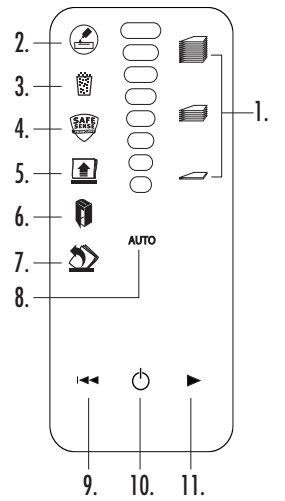

## CAPABILITIES

**Will shred:** Paper, 132 column continuous form, plastic credit cards, CD/DVDs, staples, paper clips and junk mail

**Will not shred:** Adhesive labels, transparencies, newspaper, cardboard, large paper clips, laminates, file folders, X-rays or plastic other than noted above

### Paper shred size:

Cross-Cut (425Ci, 485Ci).....5/32 in. x 1-1/8 in. (4mm x 30mm)  
Strip-Cut (425i, 485i).....7/32 in. (5.8mm)













### Maximum:

Sheets per pass (Cross-cut)..... 30\*  
Sheets per pass (Strip-cut) ..... 38\*  
CDs/Cards per pass ..... 1\*  
Paper entry width (485Ci, 485i) ..... 16 in. (407mm)  
Paper entry width (425Ci, 425i) ..... 12 in. (305mm)

\*8.5"x11", 20lb., (75g) paper at 120V, 60 Hz, 12Amps; heavier paper, humidity or other than rated voltage may reduce capacity. Maximum recommended daily usage rates: 11,000 (425Ci/485Ci) / 10,000 (425i/485i) sheets, 500 credit cards; 50 CDs.

Fellowes SafeSense® shredders are designed to be operated in office environments ranging between 50 – 80 degrees Fahrenheit (10 – 26 degrees Celsius) and 40 – 80% relative humidity.

## WARNING: IMPORTANT SAFETY INSTRUCTIONS — Read Before Using!

-  Operation, maintenance, and service requirements are covered in the instruction manual. Read the entire instruction manual before operating shredders.
-  Keep away from children and pets. Keep hands away from paper entry. Always set to off or unplug when not in use.
-  Keep foreign objects – gloves, jewelry, clothing, hair, etc. – away from shredder openings. If object enters top opening, switch to Reverse (←) to back out object.
-  Never use aerosol products, petroleum based lubricants or other flammable products on or near shredder. Do not use canned air on shredder.
-  Do not use if damaged or defective. Do not disassemble shredder. Do not place near or over heat source or water.
-  This shredder has a Disconnect Power Switch (G) that must be in the ON (I) position to operate shredder. In case of emergency, move switch to OFF (O) position. This action will stop shredder immediately.
-  Avoid touching exposed cutting blades under shredder head.
-  Use only designated entry for CDs/cards. Keep fingers away from CD entry.
-  Do not put foreign objects in paper entry.
-  Shredder must be plugged into a properly grounded wall outlet or socket of the voltage and amperage designated on the label. The grounded outlet or socket must be installed near the equipment and easily accessible. Energy converters, transformers, or extension cords should not be used with this product.
-  FIRE HAZARD – Do NOT shred greeting cards with sound chips or batteries.
-  For indoor use only.
-  Unplug shredder before cleaning or servicing.

## BASIC SHREDDING OPERATION

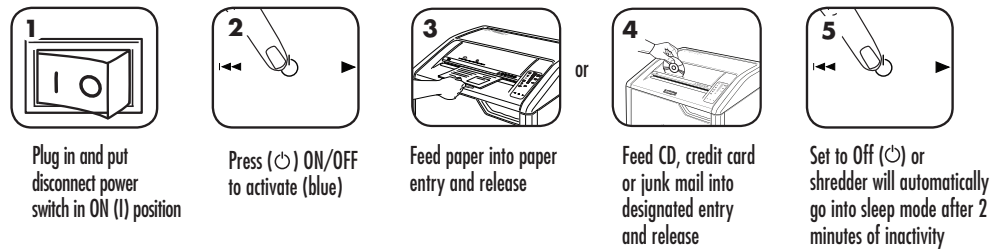

## ADVANCED PRODUCT FEATURES



## 100% JAM PROOF SYSTEM OPERATION\*

Eliminates paper jams and powers through tough jobs.

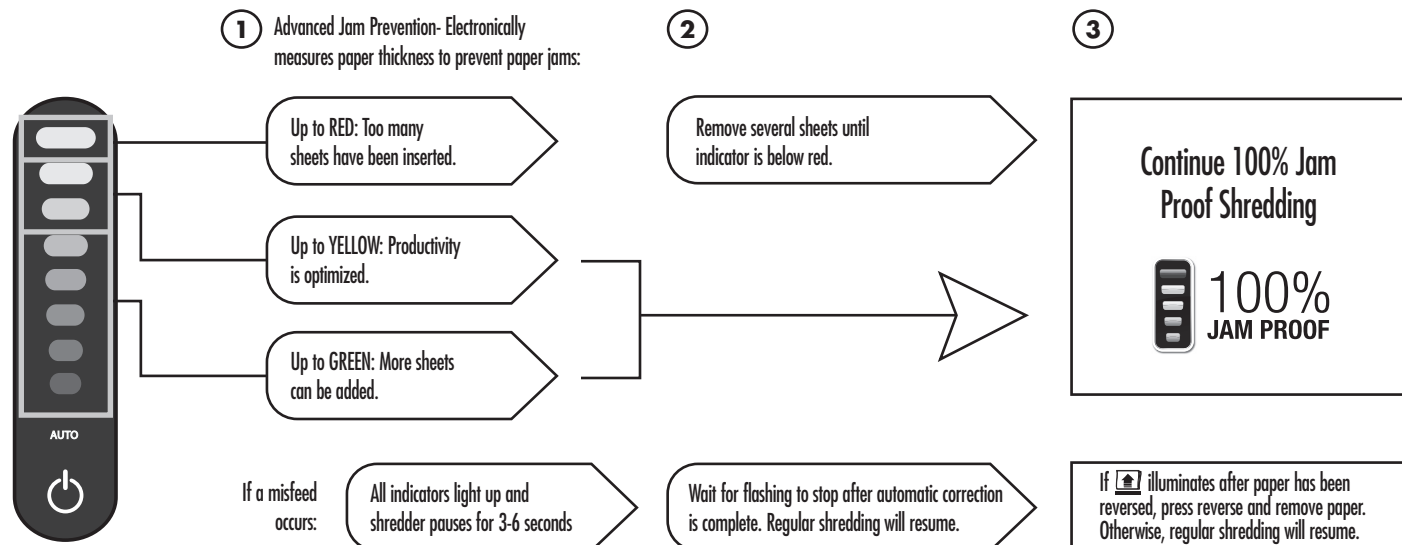

## STRAIGHT FEED



\*100% Jam Proof when used in accordance with user manual

## AUTO OIL™ OPERATION

Lubricates the cutters automatically to enhance performance and extend shredder life (Auto oil system is only included on cross-cut models - 425Ci and 485Ci.)

### SET-UP AND TESTING

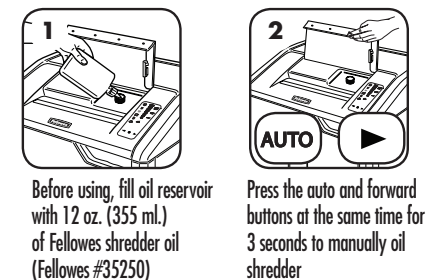

### REFILLING OIL

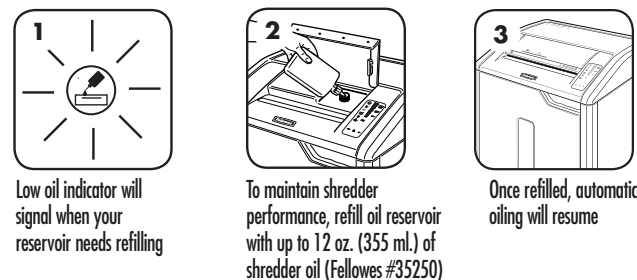

3

ENGLISH  
Models 425Ci/425i/485Ci/485i

## ADVANCED PRODUCT FEATURES



### SET-UP AND TESTING

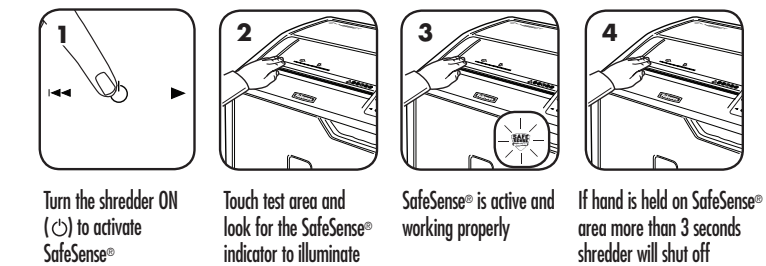

For more information about all of Fellowes Advanced Product Features go to [www.fellowes.com](http://www.fellowes.com)

## PRODUCT MAINTENANCE

### CLEANING AUTO-START INFRARED SENSORS

Paper detection sensors are designed for maintenance free operation. However, on rare occasions, the sensors may become blocked by paper dust causing the motor to run even if there is no paper present. (Note: two paper detection sensors are located in the center of the paper entry.)

### TO CLEAN THE SENSORS

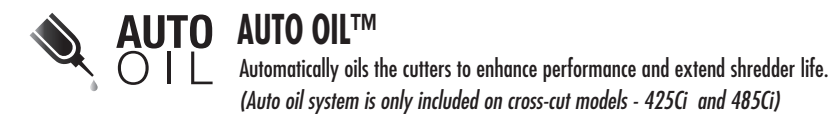
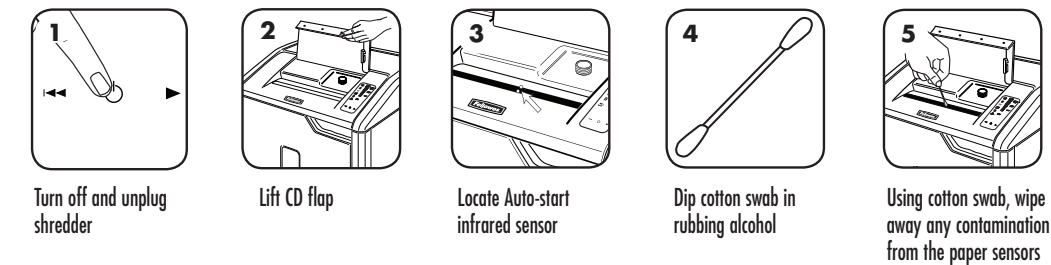

### REFILLING THE OIL

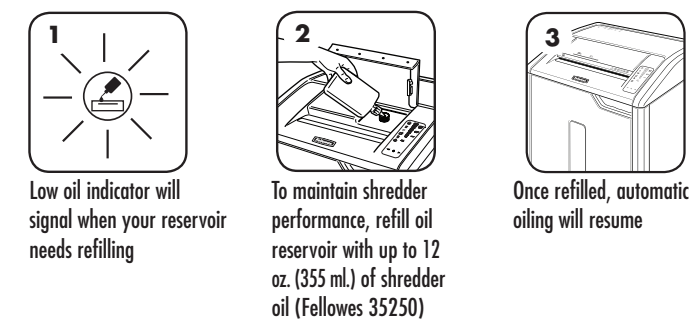

- All cross-cut shredders require oil for peak performance. If not oiled, a machine may experience diminished sheet capacity, intrusive noise when shredding and could ultimately stop running. We recommend that you refill the Auto Oil™ reservoir as instructed for optimum performance.
- If shipping shredder, oil must be drained. Open cabinet door and remove basket to access oil drain plug. Place suitable container under drain, remove plug and let oil drain out. Replace plug.

4